

## **D391A IC Designer’s Kit Guide**

### **Introduction:**

Rogers DUREL® D391A IC Designer’s Kit is intended to aid you in developing an EL lamp driver configuration using the DUREL D391A IC driver which meets your power draw budget while achieving your luminance requirements from the EL lamp. A list of components contained in the kit is in Table 1.

<b>Table 1: List of Components</b>	
Description	Qty
D391A IC Unit Samples	5
D391A IC Designer’s Kit Board	1
Kit Board Power Connector	1
EL Lamp Sample With Connector	1
Assorted SMT Inductors	>2
SMT Adapter Boards	2
Leaded CHF/CLF Capacitors – Various Values	>2
Bypass cap: 1.0uF	1

### **The D391A IC Designer’s Kit Board:**

The Designer’s Kit Board, shown in Figure 1 below, which comes with a D391A IC already soldered to the board, is a useful tool for optimizing a D391A IC driver circuit for any application. Refer to the D391A IC datasheet as a guideline with sample circuits as a starting point of your design. Simply insert an appropriate value of inductor (L) and timing capacitors (CLF and CHF) into the labeled sockets, as shown in Figure 1, to complete your driving circuit. Additional sockets are provided in the Designer’s Kit Board for a bypass capacitor between V+ and ground (GND) to absorb electrical noise in the DC input.

A jumper header on the Designer’s Kit Board is normally attached to connect E to V+ or GND. This jumper header can be removed to control the enable pin (E) with an externally supplied signal. Make sure that an appropriate load is connected between the output (Vout) and GND before applying power to the chip through the Designer’s Kit Board power connections. A sample DUREL 3 PROTOLIGHT® EL lamp is provided in the Designer’s Kit. This lamp may be cut to your required lit area.

The user can easily replace all the external components with different values on the Designer’s Kit Board in order to achieve design goals. A selection of standard values of capacitors and inductors are included in the D391A IC Designer’s Kit for your use.

---

The information contained in this data sheet is intended to assist you in designing with Rogers EL systems. It is not intended to and does not create any warranties, express or implied, including any warranty of merchantability or fitness for a particular purpose or that the results shown on the data sheet will be achieved by a user for a particular purpose. The user should determine the suitability of Rogers’ EL systems for each application.

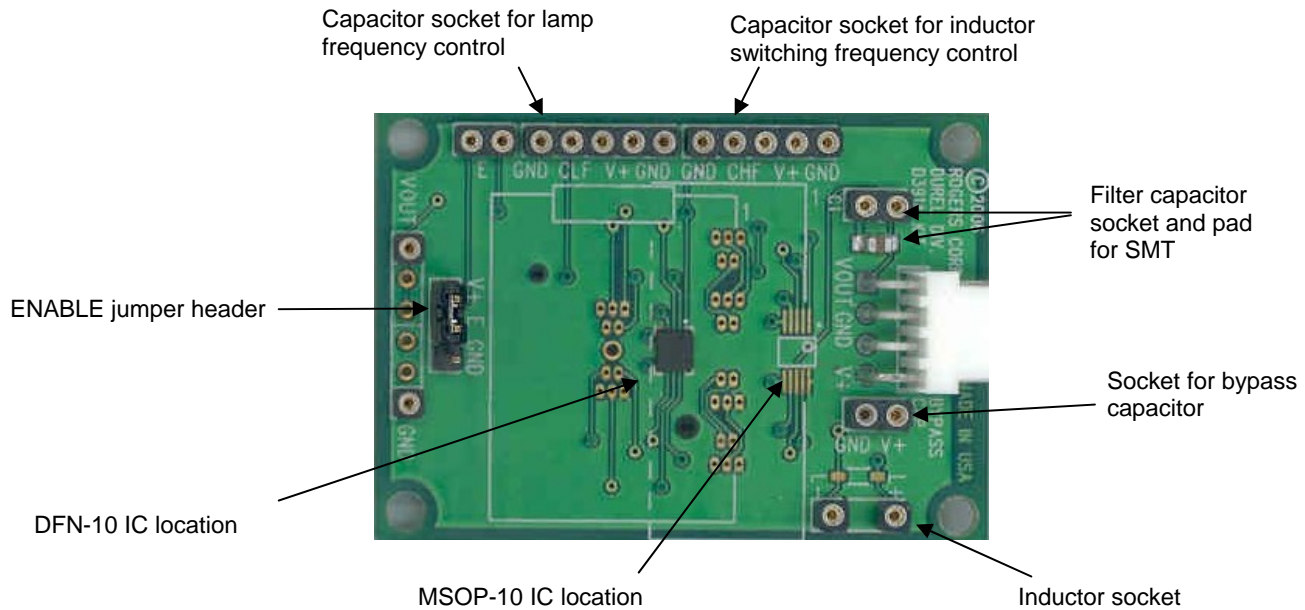

**Figure 1 – D391A IC Designer’s Kit Board**

---

**ISO 9001:2000, ISO/TS 16949:2002, and ISO 14001:1996 Certified**

The information contained in this data sheet is intended to assist you in designing with Rogers EL systems. It is not intended to and does not create any warranties, express or implied, including any warranty of merchantability or fitness for a particular purpose or that the results shown on the data sheet will be achieved by a user for a particular purpose. The user should determine the suitability of Rogers' EL systems for each application.

*Rogers EL drivers are covered by one or more of the following U.S. patents #5,313,141; #5,789,870; #5,677,599; #6,043,610, #7,009,346. Corresponding foreign patents are issued or pending.*

---

The world runs better with Rogers. is a licensed trademark of Rogers Corporation  
 DUREL and PROTOLIGHT are licensed trademarks of Rogers Corporation  
 ©2007 Rogers Corporation. Printed in U.S.A

**The world runs better with Rogers.™**

All Rights Reserved  
 Revised 11/06 Publication # LIT-I9077 A01

---