

D372A IC Designer’s Kit Guide

Introduction:

Rogers DUREL® D372A IC Designer’s Kit is intended to aid you in developing an EL lamp driver configuration using the DUREL D372A IC driver which meets your power draw budget while achieving your luminance requirements from the EL lamp. A list of components included in the kit is shown below in Table 1.

Table 1—List of components

Description	Qty
D372A IC Unit Samples	5
D372A IC Designer’s Kit Board	1
D372A IC Mini-Module Board	1
Kit Board Power Connector	1
EL Lamp Sample with Connector	1
Assorted SMT Inductors	>2
SMT Adapter Boards	5
Leaded CHF Capacitors – Various Values	>2
Bypass cap: 1.0uF	1

The D372A IC Designer’s Kit Board:

The Designer’s Kit Board, shown in Figure 1 below, comes with a D372A IC already soldered to the board. The Designer’s Kit Board is a useful tool for optimizing a D372A IC driver circuit for any application. Refer to the D372A IC datasheet as a guideline with sample circuits as a starting point of your design. Simply insert an appropriate value of inductor (L) and timing capacitors (CLF and CHF) into the labeled sockets, connect a high voltage storage capacitor (Cs) and your choice of wave-shaping resistor (RD) to complete your driving circuit. Additional sockets are provided in the Kit Board for a bypass capacitor between V+ and ground (GND) to absorb electrical noise in the DC input.

A jumper header on the Designer’s Kit Board is normally attached to connect E to V+ or GND. This jumper header can be removed to control the enable pin (E) with an externally supplied signal. Make sure that an appropriate load is connected between EL1 and EL2 before applying power to the chip through the Designer’s Kit Board power connections. A sample DUREL 3 PROTOLIGHT® EL lamp is provided in the Designer’s Kit. This lamp may be cut to your lit area as needed.

The user can easily replace all the external components with different values on the Designer’s Kit Board in order to achieve design goals. A selection of standard values of capacitors and inductors are included in the D372A IC Designer’s Kit for your use.

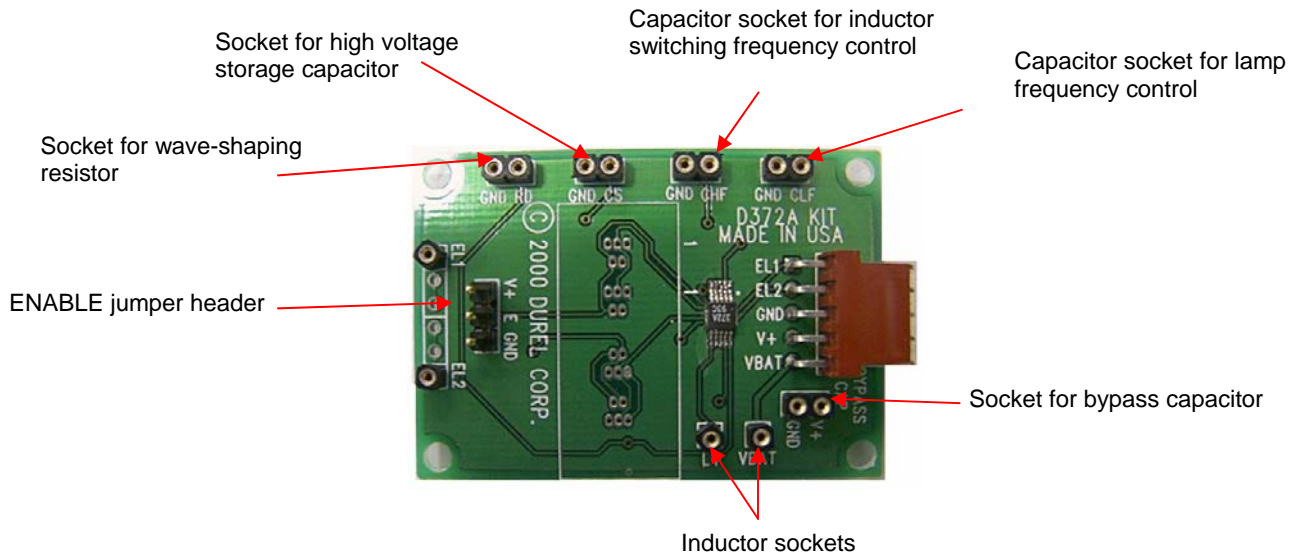

Figure 1—The D372A IC Designer's Kit Board

The D372A IC Mini-Module Board:

The D372A IC Mini-Module Board, shown below in Figure 2, is an example of a finished circuit based on the D372A IC chip. It is meant as a representation of the board area requirement for the EL lamp driver circuit in the application. All external components, except the inductor, have been selected and pre-soldered onto the module board. The mini-module board can be configured to fit into finished product for demos.

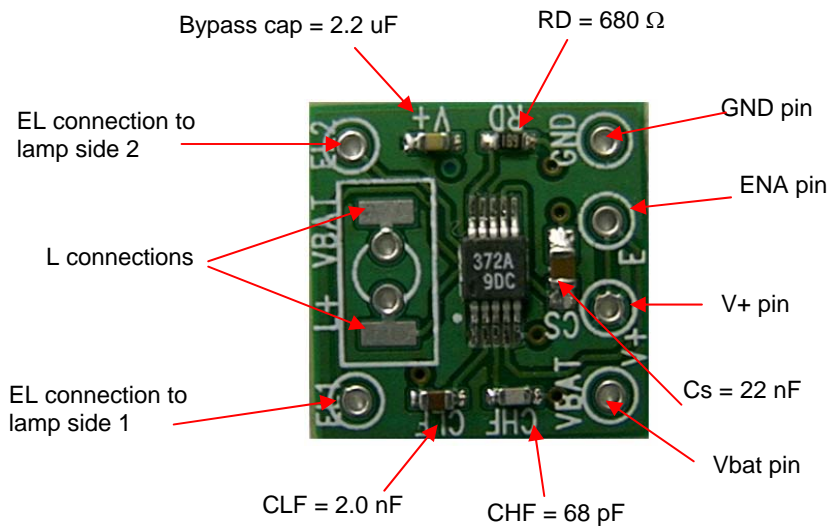

Figure 2—D372A IC Mini-Module Board

ISO 9001:2000, ISO/TS 16949:2002, and ISO 14001:1996 Certified

The information contained in this data sheet is intended to assist you in designing with Rogers EL systems. It is not intended to and does not create any warranties, express or implied, including any warranty of merchantability or fitness for a particular purpose or that the results shown on the data sheet will be achieved by a user for a particular purpose. The user should determine the suitability of Rogers' EL systems for each application.

Rogers EL drivers are covered by one or more of the following U.S. patents #5,313,141; #5,789,870; #5,677,599; #6,043,610, #7,009,346. Corresponding foreign patents are issued or pending.

The world runs better with Rogers.®

The world runs better with Rogers. is a licensed trademark of Rogers Corporation
DUREL and PROTOLIGHT are licensed trademarks of Rogers Corporation
©2007 Rogers Corporation. Printed in U.S.A
All Rights Reserved
Revised 03/07 Publication # LIT-I9036 A05